

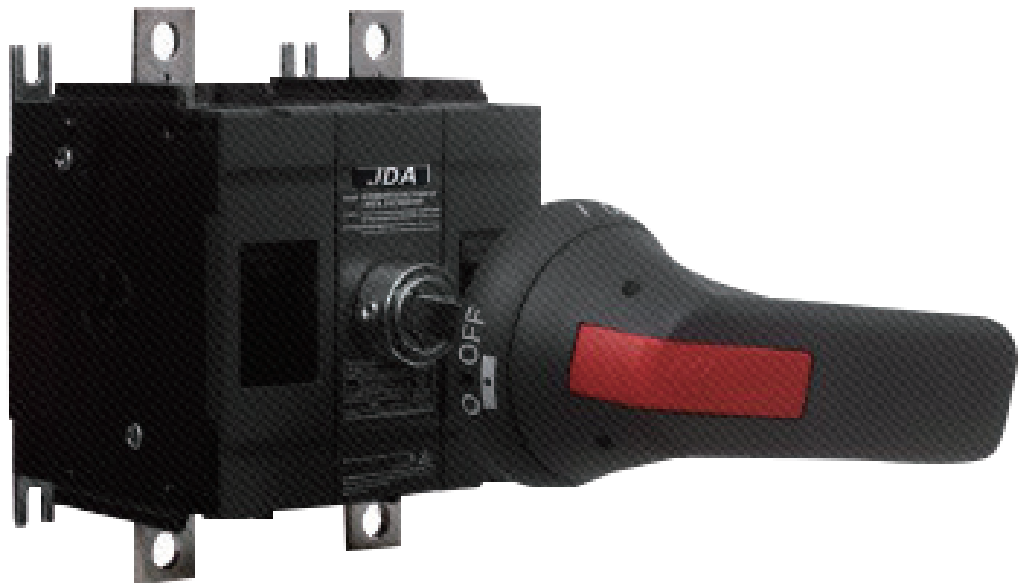

日揚國際事業股份有限公司
JD Auspice Co., Ltd.

JDA-DS3VH 400/500/630 (G) & JDA-DS3VH 325/400 (U) Product Specifications





CONTENTS

1. Scope of application and use	3
2. Product models	3
3. Main technical parameters	4
4. Environment	6
5. Product appearance and installation dimensions	7
6. Installation requirements and packaging storage	11
7. Accessories list and installation	11
8. Precautions	13



1. Scope of application and use

1.1 Application

JDA-DS3VH 400/500/630 (G) & JDA-DS3VH 325/400 (U) isolating switch is suitable for low voltage distribution network with DC1500V and below, rated working current of 630A and below, as a switch for infrequently making and breaking circuits and lines. for isolation. It can provide open circuit and overload protection functions.

1.2 Product pictures

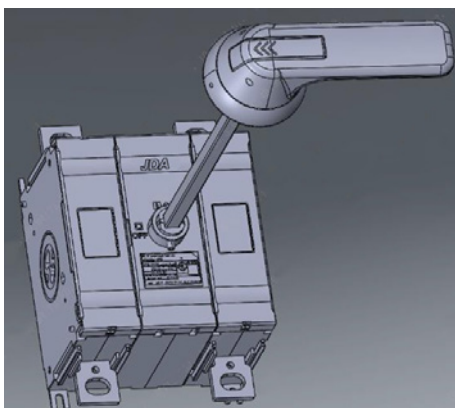

JDA-DS3VH 400/2/11ZP

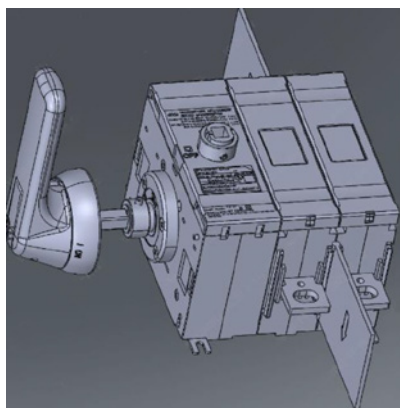

JDA-DS3VH 400/2/02CP

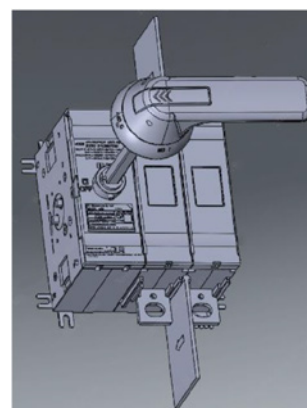

JDA-DS3VH 400/2/02ZP

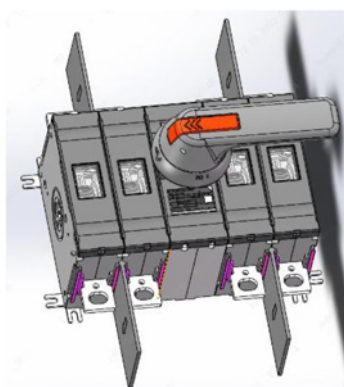

JDA-DS3VH 400/4/22ZP

2. Product models

2.1 Certified Models

JDA-DS3VH 325/400 (U) UL

JDA-DS3VH 400/500/630 G CCC/CE/TUV



2.2 Model Explanation

JDA - DS 3 V H - / / / /
 1 2 3 4 5 6 7 8 9 10 11

No.	Code name	Code description
1	Enterprise code	Enterprise code: JDA
2	Product Code	Disconnecting switch
3	Design code	3V
4	Design code	H High parameter
5	Rated current (A)	In UL 325/400 CCC/CE/TUV 325/400/500/630
6	Number of poles	2: 2 poles 4: 4 poles
7	Mechanism splicing	02: 2 poles/mechanism left; 11: 2 poles/body centering 22: 4 poles/body centering (two circuit)
8	Operation mode	Z: Standard operation C: Side operation
9	Handle type	P: No handle (with handle outside the switchgear, it needs to be ordered separately, see "Handle + Shaft with Standard Accessories" for details) K: Directly operate the handle in the switchgear
10	Certified type	G CCC/CE/TUV U UL
11	Foot installation	01: Regular 1, 02: Regular 2, 03: Regular 3

3 Main technical parameters

3.1 Compliance with standards

GB/T 14048.1 ; GB/T 14048.3 ;
 IEC 60947-1 ; IEC 60947-3 ;
 UL98B



3.2 Technical parameters

Parameters	Parameter Description															
Frame size current (A)	GB: 400/500/630 UL: 325A/400															
Rated current (A)	UL Certification : <table border="1" style="margin-left: 20px;"> <tr> <td>Frame size</td> <td>325</td> <td>400</td> </tr> <tr> <td>Rated current</td> <td>325</td> <td>400</td> </tr> </table> CCC/CE/TUV Certification : <table border="1" style="margin-left: 20px;"> <tr> <td>Frame size</td> <td>400</td> <td>500</td> <td>630</td> </tr> <tr> <td>Rated current</td> <td>325</td> <td>400</td> <td>500</td> <td>630</td> </tr> </table>	Frame size	325	400	Rated current	325	400	Frame size	400	500	630	Rated current	325	400	500	630
Frame size	325	400														
Rated current	325	400														
Frame size	400	500	630													
Rated current	325	400	500	630												
Rated voltage	DC 1000V / DC 1500V															
Insulation voltage Ui	1500V															
Rated short circuit making capacity Icm	CCC/CE/TUV:20kA/0.15s,10kA/1s UL 10kA/50ms															
Limiting short circuit current (Iq) (fuse) ①	30kA															
Rated impulse withstand voltage Uimp	12kV															
Protection class	IP66 outside the switchgear , IP20 inside the switchgear															
Operation method	Standard operation, side operation (side operation is an extended operation method)															
Electrical endurance	400times (400A and above 200 times)															
Mechanical endurance ②	Standard operation 10000times Side operation 2500times extended operation method															
Usage category ③	CCC/CE/TUV: DC 21B/PV1 UL UL98B															
Wiring capability(M8)	CCC/CE/TUV: JDA-DS3VH 630 185mm ² copper wire 2 or 40×5mm copper bar 2 JDA-DS3VH 500 150mm ² copper wire 2 or 30×5mm copper bar 2 JDA-DS3VH 400 240mm ² copper wire 1 UL : JDA-DS3VH-400 Wide:32mm thickness:4mm copper bar:2 or equivalent cross sectional area Auxiliary switch:0.75 2.5mm ²															
Terminal tightening torque (Tightening torque)	main circuit:22N.m Auxiliary circuit:0.8 N.m															
Certification	CCC/CE/TUV UL															

Note: No. ① is under DC415; No. ② means maintenance mechanical endurance, otherwise according to GB or UL standards No. ③ , PV1 category does not include side operated models



4. Environment

4.1 Environmental Requirements

Environmental Requirements	Description
Ambient temperature	-40°C ~ +85°C, when the ambient temperature is above +70°C, derating is required. The derating factor is as follows
Altitude	Below 5000 meters, when the altitude is 2000m 5000m, derating is required. The derating factor is as follows
Pollution level	Pollution level 3; in a medium without explosion hazard, and the medium has no gas and conductive dust enough to corrode metals and destroy insulation; in a place without rain and snow
Protection class	IP20 inside the switchgear, IP66 outside the switchgear

(1) Altitude : below 5000 meters

JDA-DS3VH 400/500/630 (G) & JDA-DS3VH 325/400(U) Altitude derating factor table						
Altitude	2000m	2500m	3000m	3500m	4000m	5000m
Power frequency withstand voltage	4000V	4000V	4000V	4000V	4000V	3500V
Working current correction factor	1	0.96	0.93	0.90	0.88	0.82
Working voltage correction factor	1	1	1	1	1	1

(2) Ambient temperature:-40°C ~ +85°C

JDA-DS3VH 400/500/630 (G) & JDA-DS3VH 325/400 (U) Ambient temperature derating coefficient table				
Ambient temperature	70°C	75°C	80°C	85°C
Power frequency withstand voltage	4000V	4000V	4000V	4000V
Working current correction factor	1	0.95	0.92	0.88
Working voltage correction factor	1	1	1	1

(3) In a non explosive medium, and the medium has no gas and conductive dust enough to corrode metals and destroy insulation; in a place without rain and snow.

5. Product appearance and installation dimensions

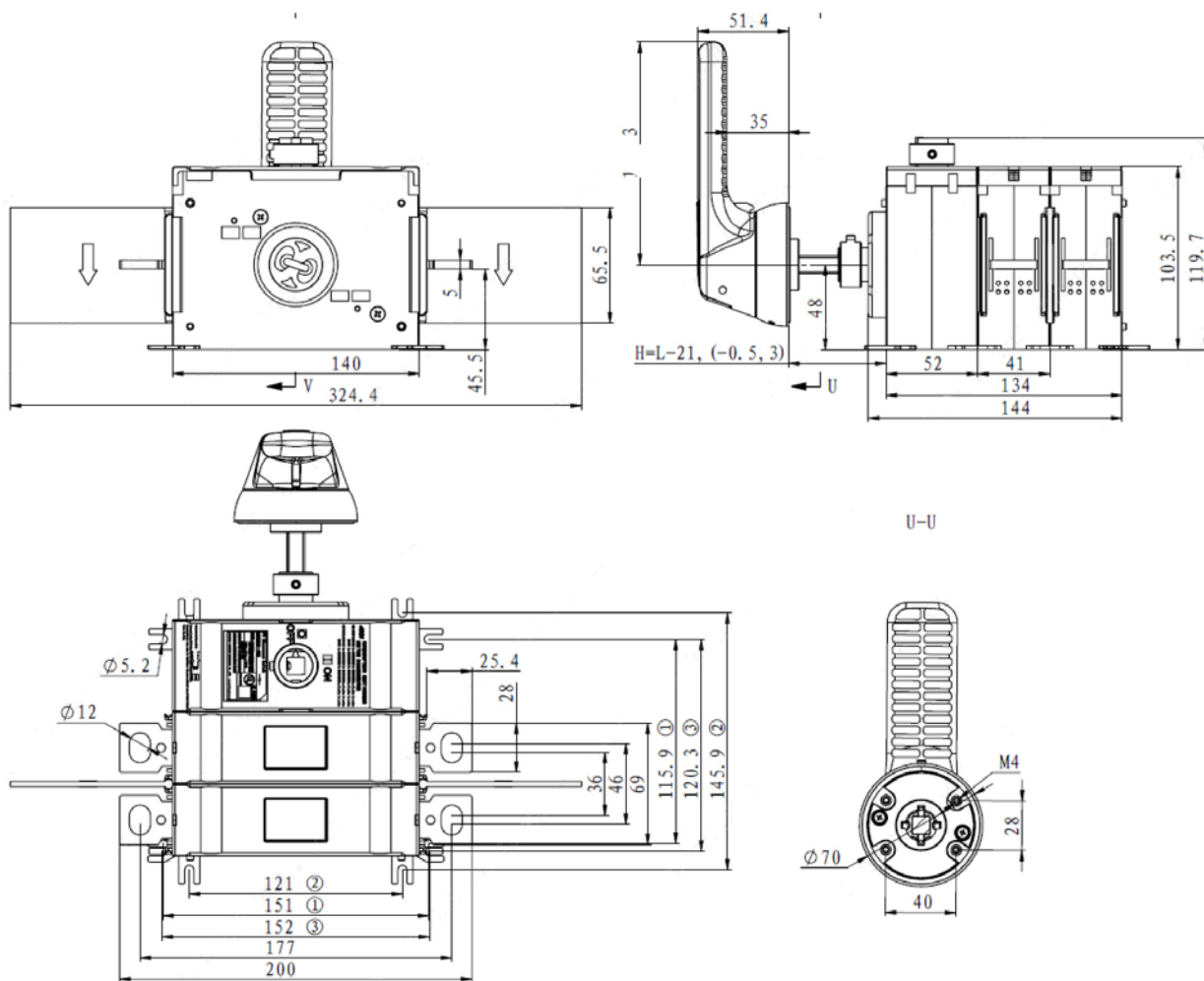

Side operation outline installation drawing

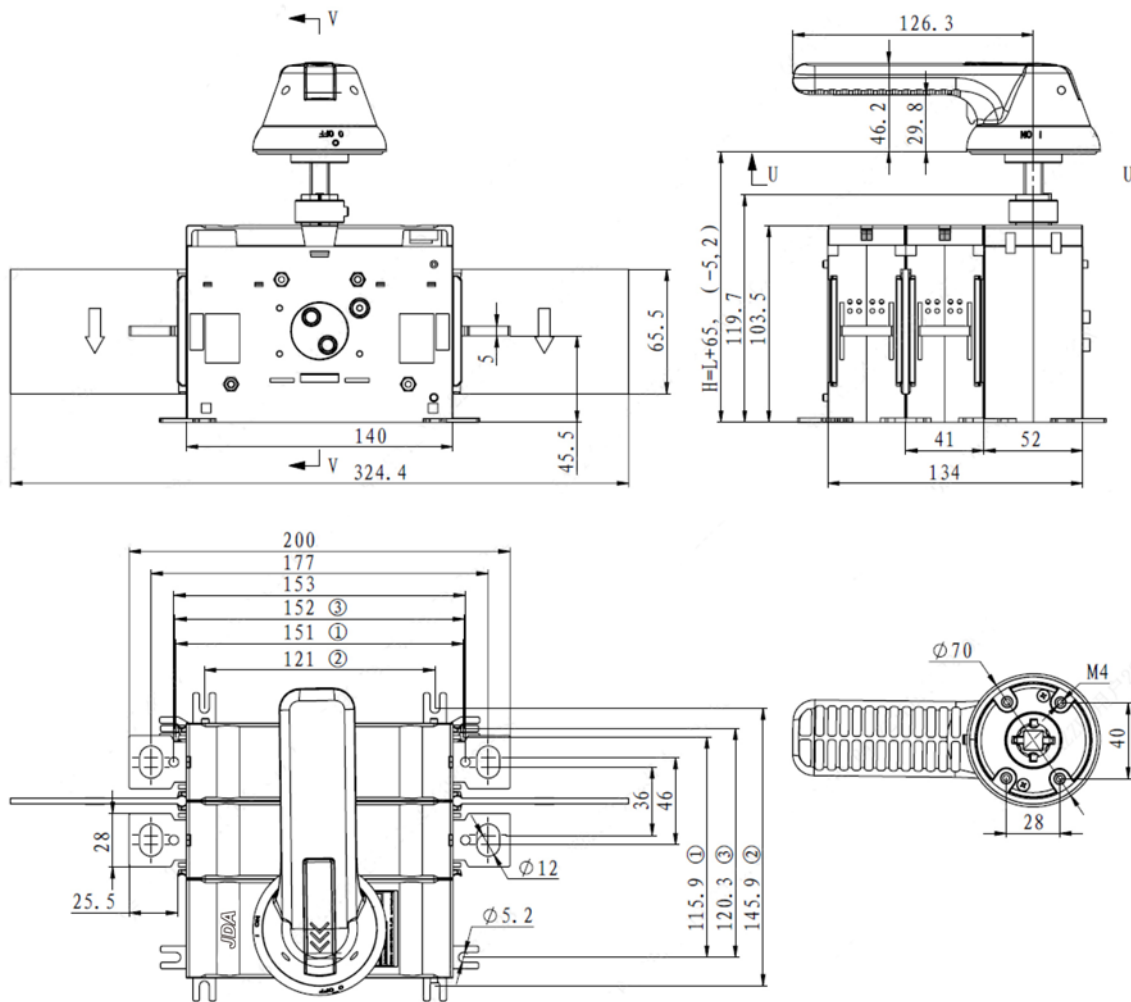

Standard operation outline installation drawing

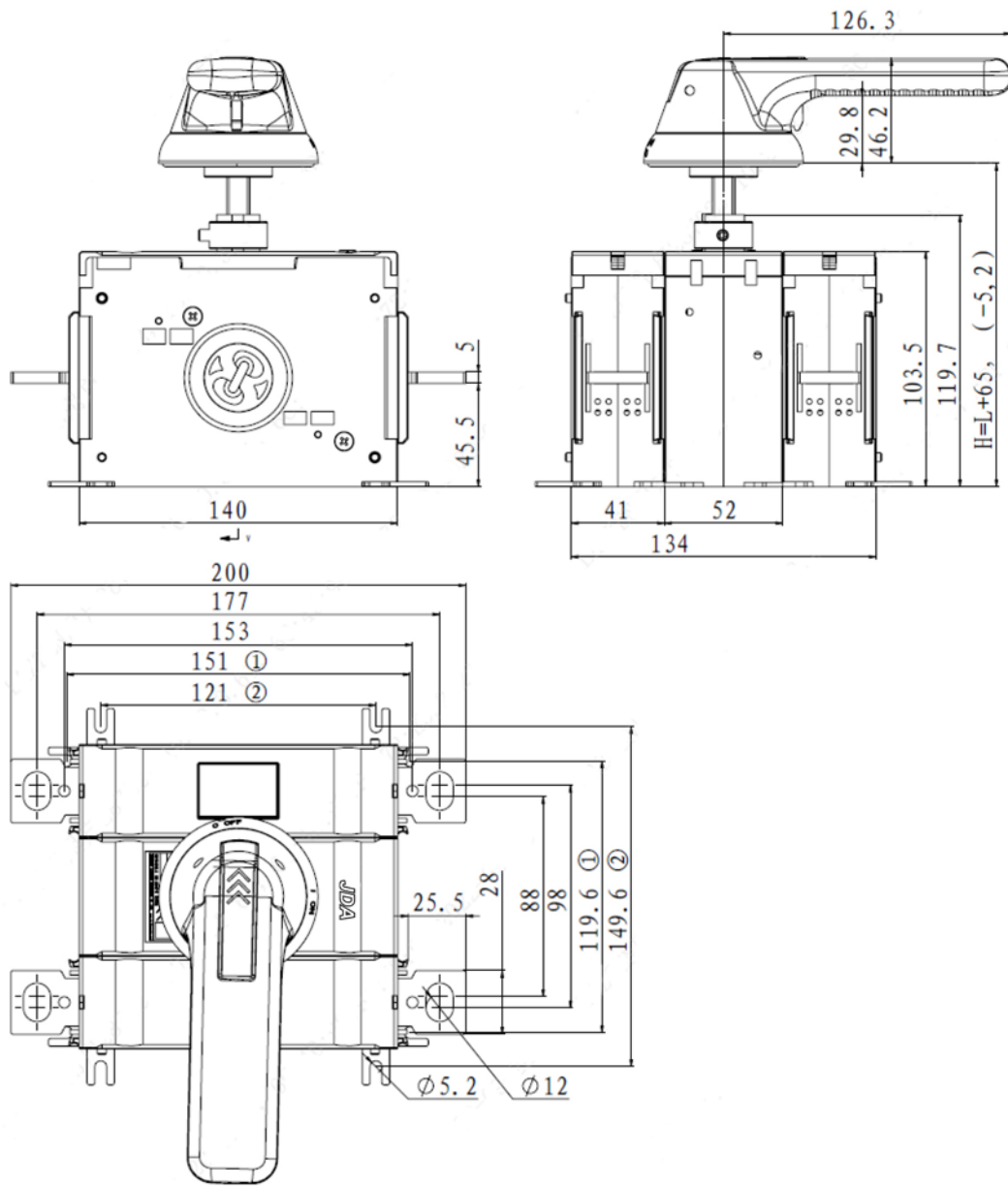

Standard Operation (Mechanism Centered) Outline Installation Drawing

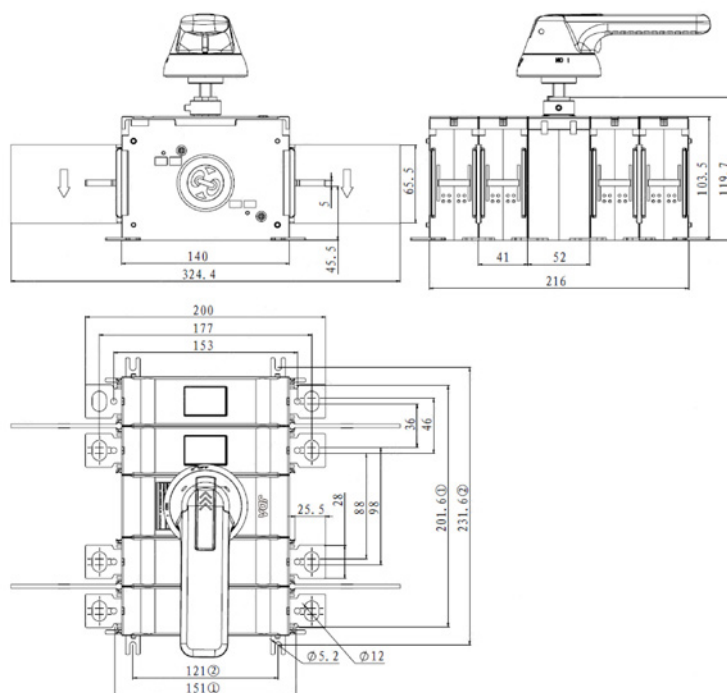

Standard Operation (Mechanism Centered) Outline Installation Drawing

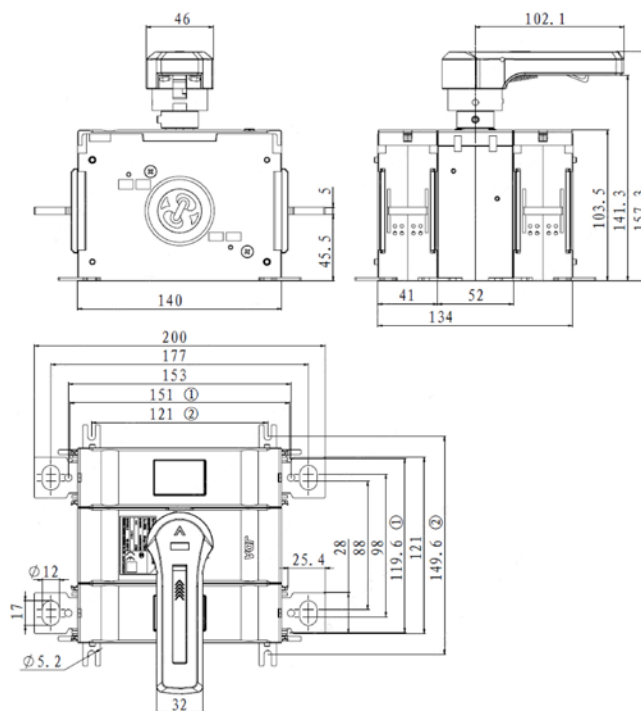

Forward operation (center of cabinet mechanism) Outline installation drawing (opening)

Note: For the optional length “L” of the square shaft of the handle outside the cabinet, see the description of the handle model in 7.1.1;

For each shape, the serial numbers ① and ② on the foot installation dimension mark represent the normal 1 and normal 2 in the 10th bit of the 6.2 Model Explanation. If there is no special requirement, the default is the normal 1 installation method.

When operating directly in the cabinet, due to the lack of protection of the cabinet door or box, it is not allowed to operate with load for personal safety.



6. Installation requirements and packaging storage

6.1 Installation

It should be installed in a place where there is no explosion hazard, no conductive dust, and no enough to corrode metals and damage insulation. Use M5 screws to fix the 4 feet of the isolation switch to the installation panel or switchgear.

6.2 Packaging and storage

The material used for product packaging: plastic bag sealing, silica gel desiccant, double corrugated paper for the box, and pearl cotton for the buffer;

Storage environment and period: The product should be stored in a warehouse where the ambient temperature is 40°C to +85°C, the relative humidity (ambient temperature +25°C) is below 95%, and there is no acid, alkaline or other corrosive gas in the surrounding air. Storage, under the above conditions, the storage period shall not exceed 36 months from the date of manufacture.

7. Accessories list and installation

7.1 List of optional accessories

No.	Name	Type	Accessory product installation and quantity
1	Handle	In switchgear	It is installed on the switchgear door and connected to the product body through a square shaft. Shaft length optional unit (mm)
		Out switchgear	Used in the switchgear, installed on the product, direct operation
2	Auxiliary contacts Installed		Installed on the left front of the main switch, up to 2
3	Shorting bar		Installed on the terminal board of the main switch
4	Heat sinker		Installed on the terminal board of the main switch

7.1.1 Handle model explanation

SB 1 - □ / □
1 2 3 4

No.	Serial number description	Code description
1	Function code	SB handle
2	Design number	1
3	Square shaft code	Square shaft length, unit mm, optional 77, 88, 120 150, 182, 200, 275, 300, 350, 385, 400, 504, 650
4	Handle category	1: Outside the front control switchgear; 2: Outside the side control switchgear 3: Inside the front operation switchgear; 4: Inside the side operation switchgear

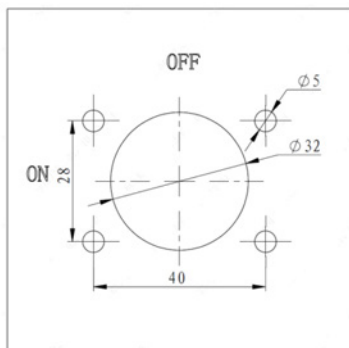

Recommended opening diagram for the switch gear door of the side operating handle outside the SB1 switchgear, the torque of the 4×M4 mounting screws is 1.5 1.6N.m

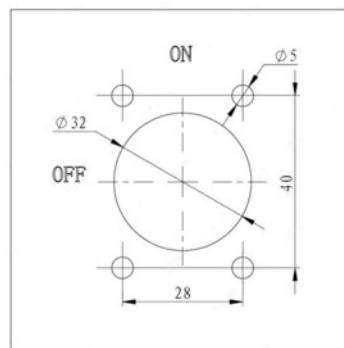

Recommended opening diagram for the switchgear door of the standard operating handle outside the SB1 switchgear, the torque of the 4×M4 mounting screws is 1.5 1.6N.m

7.1.2 Auxiliary contact model explanation

F 1 - □ / □
1 2 3 4

No.	Serial number description	Code description
1	Function code	Auxiliary contact
2	Design number	1
3	Contact form	01: normally closed structure 10: Normally open structure 11: Normally open normally closed structure
4	Size	G: Auxiliary contacts according to CCC/CE/TUV standards U: Auxiliary contact according to UL standard
5	Installation Quantity	1: Install one per product 2: Install two per product

Electrical parameters in line with UL standards:

Rated working voltage	AC125V	AC250V
Rated working current	20.5A	20.5A

Rated insulation voltage: AC1000V

Conventional heating current: I_{th}: 20.5A

Rated frequency: 50/60Hz

Use category: AC-15

Protection class: IP20

Electrical life: 20000 times

Minimum load: DC24V, 5mA

UL Compliant, RoHS Compliant



Electrical parameters in line with CCC/CE/TUV standards:

Rated working voltage	AC230V	AC400V	AC690V	DC220V
Rated working current	6A	4A	2A	0.6A

Rated insulation voltage: AC690V
 Rated impulse withstand voltage U_{imp} : 4kV
 Conventional heating current: I_{th} : 16A
 Rated frequency: 50/60Hz
 Use category: AC-15, DC-13
 Protection class: IP20
 Electrical life: 20000 times
 Minimum load: DC24V, 5mA
 Standard certification: GB/T 14048.5, RoHS compliant

8. Precautions

- (1) The quality problems caused by the unauthorized disassembly of the product are at your own risk.
- (2) In the working power on state, do not touch the exposed part of the non insulating part of the isolating switch.
- (3) The connecting wire should be fastened on the power distribution switchgear frame. The switch should not bear the weight of the wires. Before tightening the wires, the plane of the busbar or cable terminals should be parallel to the plane of the switch terminals. After bolting the wires to the switch terminals, the switch should not be subjected to various mechanical stresses.
- (4) The wiring must be reliable to prevent the terminal of the isolation switch from burning due to abnormal heating of the terminal.



日揚國際事業股份有限公司
JD Auspice Co., Ltd.



 www.jdauspice.com



 [@jdauspice](https://www.facebook.com/jdauspice)



 ID : @jdapv

